



Rugged, Safe and Efficient Roof Venting

Superior Airflow Efficiency

NEW



Advanced Model 477

Model DJK477KR

THE CODE COMPLIANT CHOICE

Venting the dryer through the roof can help shorten duct run length and improve efficiency. Until now, however, roof terminations were too restrictive or included code-prohibited screens.

Today, you can select roof vents that are specifically designed for the dryer. The DryerJack® minimizes airflow restriction and meets or exceeds all code requirements.

IMC 504.4 & IRC 1502.3 Compliant



DryerJack 477—Low Profile Efficiency

DryerJacks are efficient. Better airflow performance is achieved through advanced engineering including damper curvature, hood size and collar placement.

DryerJack model 477 is deep draw manufactured in the U.S. from heavy gauge Galvalume®. At less than 5" tall, it delivers safe venting through the roof and low profile aesthetics.

DryerJack 486—Extra Clearance

When you need room for high profile tile or to accommodate heavy snowfall, select model DJK486. It's nearly as efficient as model 477 but provides more clearance above the roof.

Key DryerJack Benefits

- Closure Design Deters Bird and Rodent Entry
- Collar and Curved Damper Maximize Airflow
- Rounded Flange Corners and Nail Holes Ease Handling and Installation
- Access Door Accommodates Cleaning Tools
- **DJK477:** Low Profile Improves Aesthetics
- **DJK486:** Taller Profile Provides Extra Clearance



Made in the USA

Model DJK486

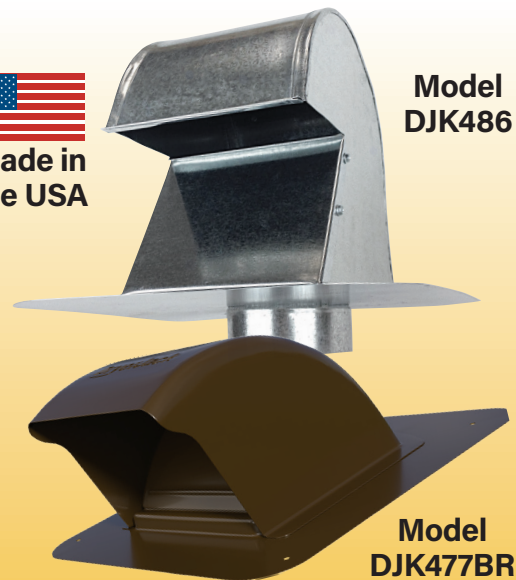

Model DJK477BR



infraAIR

(800) 707-6297

InfraAir.ca

DryerJack

Technical Product Specifications

DryerJack Model 477

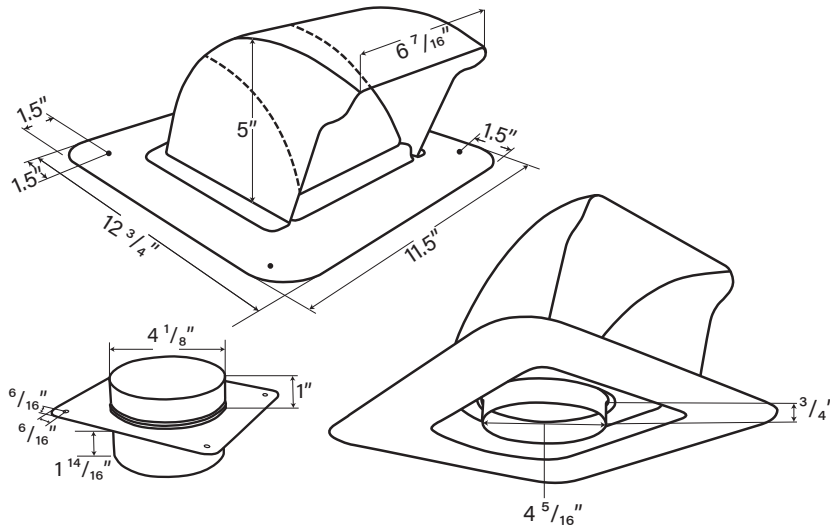

DryerJack Model 486

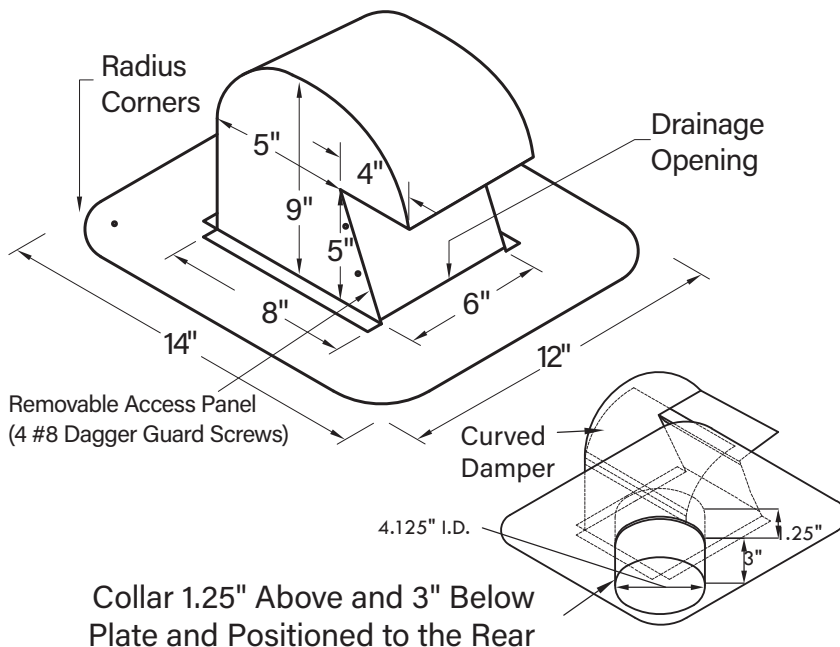

Model	Applications
DJK477	Low profile, efficient termination for safely venting the dryer through the roof.
DJK486	Extra clearance model for high profile tile or heavy snowfall zones.

Performance Data

For Use:

- Non-restrictive dryer roof vent termination
- Complies with IMC 504.4 & IRC 1502.3

Material:

- 22 gauge Galvalume® Unibody Base & Hood
- 26 gauge Galvalume® Damper (Minimizes Restriction)

Weight:

Each DJK477 / 3.75 lbs. — DJK486 4 lbs.
Carton DJK477 / 14 lbs. — DJK486 8 lbs.

General Information

Benefits:

- Venting through the roof can shorten duct length
- Improved efficiency shortens cycles, saves energy
- Damper design deters bird and rodent entry
- Access features ease duct cleaning & maintenance

Features:

- Rugged heavy gauge Galvalume
- Rounded corner nailing flange and nail holes
- Equally suitable for new and retrofit construction

Distributed By

InfraAir Products

40 Ironside Cres., Unit 2
Toronto, ON M1X 1G4 Canada
Phone: (800) 707-6297

InfraAir.ca

 **Made in the USA**