

High-Performance Low-Profile Termination



Lasting Beauty

Well-built Aesthetics

Low profile and clean lines help enhance exterior beauty. With a heavy gauge Galvanized and powder coated steel body, the DryerWallVent is made to last.

Ease of Installation

Engineered for a quick, perfect fit in both retrofit and new construction, total replacement time can be as low as four minutes.

Airflow Efficiency

The lightweight Galvalume® damper and clean opening maximize efficiency and exceed all code requirements. Less airflow restriction helps save on energy bills, and drying time.



Efficient, Low Profile Termination

- Lightweight Damper Reduces Airflow Restriction
- Integrated Magnets Deter Bird and Rodent Intrusion
- Damper Easily Accommodates Cleaning Equipment
- Gravity-Assist Damper Provides Extra Protection

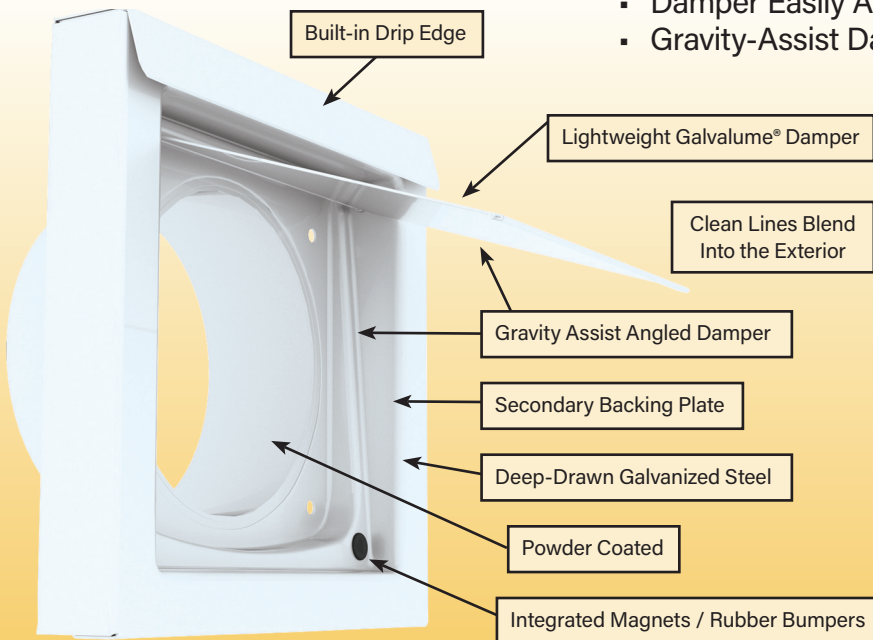

(800) 707-6297
www.InfraAir.ca



Technical Product Specifications

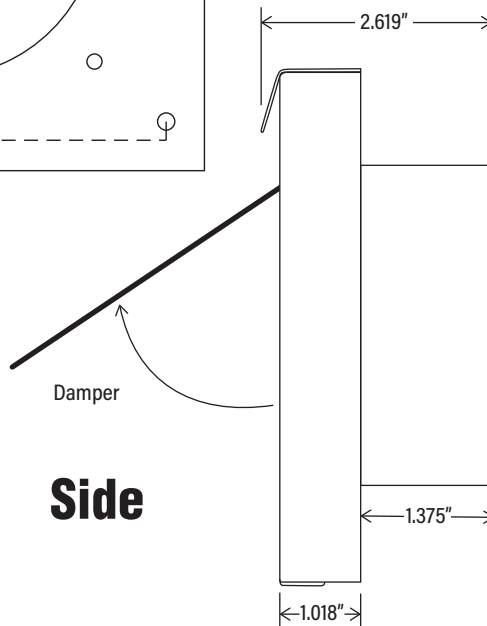
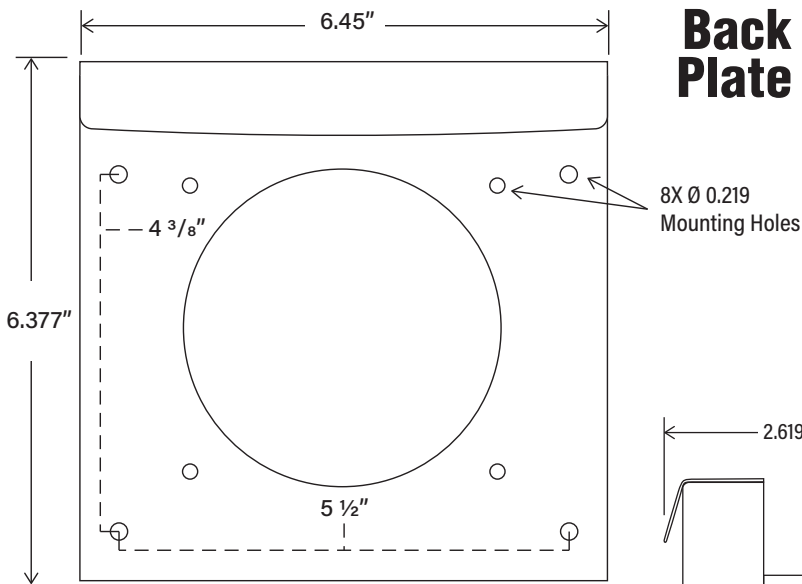
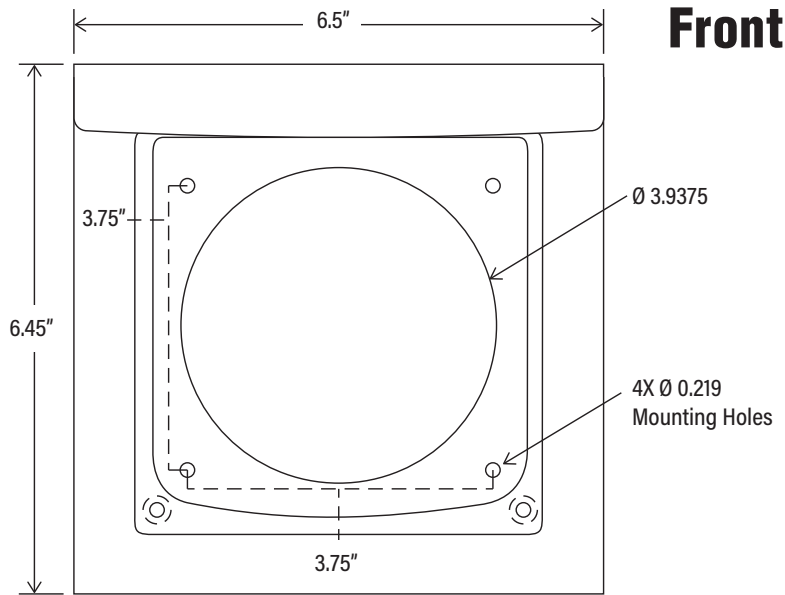

Model Number	Color
DWV4W	White
DWV4T	Tan
DWV4B	Brown
DWV4K	Black

Performance Data

Product Use:

- Venting Dryer Exhaust Systems Through Exterior Walls
- Complies w/ IMC 504.4 & IRC 1502.3

Materials:

- Heavy Gauge Galvanized Steel Housing
- Lightweight Gauge Galvalume® Damper
- Polyester TGIC Weather Resistant Powder Coating

General Information

Benefits:

- Improves Aesthetics with Flush Installation
- Installs Easily in New and Existing Construction
- Simplifies Duct Cleaning with Easy Accessibility
- Deters Bird and Rodent Entry
- Maximizes Airflow Efficiency
- Helps Minimize Dryer Cycle Times
- Extra Protection Against the Elements

Features:

- Deep Drawn Manufacturing Process
- Galvanized & Powder Coated Steel Construction
- Lightweight Damper and Heavier Frame
- Recessed Gravity Damper & Integrated Magnets
- Integrated Secondary Back Plate with Wider Mounting Holes
- Built-in Drip Edge
- Damper Opens Freely to 110°
- Low Strength Closure Magnets
- Rubber Bumpers Support Quiet Closing Damper
- Eight Built-in Mounting Holes
- **Stocked in 4 Colors: White, Tan, Brown and Black**

Distributed By

InfraAir Products

40 Ironside Cres., Unit 2
 Toronto, ON M1X 1G4 Canada
 Phone: (800) 707-6297

www.infraair.ca



Made in the USA