



@sealedunitpartscos | @supco\_hvac | supco.com  
P: 800.333.9125 | E: orders@supco.com | F: 800.458.2818

## WHEN IT COMES TO HARD STARTS, SUPCO KNOWS A THING OR TWO.

In 1972 we invented THE ORIGINAL two-wire AC hard start kit and since then, we've expanded our line to offer a hard start technology that meets every job and budget. Manufactured in our own facilities, SUPCO® hard starts are 100% quality tested off the line.



### SPP E-SERIES ELECTRONIC POTENTIAL RELAY TECHNOLOGY

Supco® Part No.	Application	Capacitor Size (µFXVAC)
SPP6E	1/2 - 3 hp	88-106 µF
SPP7E	1 - 4 hp	130-156 µF
SPP8E	1 ton and up	189-227 µF

### SPP SUPER BOOST SERIES PTC TECHNOLOGY

Supco® Part No.	Increase In Torque
SPP	250%
SPP5	300%
SPP6	500%
SPP7S	600%



### ULTRA START SERIES 2-WIRE MECHANICAL POTENTIAL RELAY HARD START

Supco® Part No.	Application	Capacitor Size (µFXVAC)	Can Substitute for Kickstart®
<b>WITHOUT RELAY COVER</b>			
SPR5	1 - 3 ton	189-227 µF	TO-5
SPR1	3.5 - 5 ton	270-324 µF	KS-1
<b>WITH RELAY COVER</b>			
MPR5	1 - 3 ton	189-227 µF	TO-5
MPR1	3.5 - 5 ton	270-324 µF	KS-1

### 3-SERIES 3-WIRE MECHANICAL POTENTIAL RELAY HARD START

Supco® Part No.	Application	Capacitor Size (µFXVAC)	Can Substitute for 5-2-1®
3W1	1 - 3 ton	88 - 108 µF	CSRU1
3W2	3.5 - 5 ton	189 - 227 µF	CSRU2
3W3	4 - 5 ton	270 - 324 µF	CSRU3

## 2 PARTS REPLACE 1-5 TONS - 3W1, 3W2



**EZ SNAP MOUNTING BRACKET**

ONLY AT  
**Supco**

## ORIGINAL SERIES

SYSTEMS WITHOUT RUN CAPACITORS



### RELAY ONLY

Supco® Part No.	Mounting
ICG1*	Quick Connect
ICG-220**	Quick Connect
PO115*	Push-On

All HP 1/12 to 1/2  
\*120 Volt \*\*240 Volt

### 3 'N 1 RELAY, OVERLOAD & START CAPACITOR COMBINATION

Supco® Part No.	Max AMPS
RCO210	13.3
RCO410	6.8
RCO810	4.0

All 120 Volt



### RELAY & OVERLOAD COMBINATIONS

Supco® Part No.	Mounting	HP Rating
RO41	Quick Connect	1/4 to 1/3
RO81	Quick Connect	1/12 to 1/5
PRO41	Push On	1/4 to 1/3
PRO81	Push On	1/12 to 1/5

All 120 Volt



## UNIVERSAL SERIES

SYSTEMS WITH OR WITHOUT RUN CAPACITORS



### UNIVERSAL 3 'N 1 RELAY OVERLOAD & START CAPACITOR

Supco® Part No.	Max AMPS
URCO210	13.3
URCO410	6.8
URCO810	4.05

All 120 Volt

### UNIVERSAL 4 'N 1 RELAY CAPACITOR, OVERLOAD & RUN CAPACITOR

Supco® Part No.	Max AMPS	Run Cap. Size $\mu$ FD
URCO210RC	13.3	20
URCO410RC	6.8	15
URCO810RC	4.0	12.5

All 120 Volt



## VG64 DIGITAL VACUUM GAUGE

- Ultra Fine Resolution
- Easy-to-Clean LIFETIME Sensor Never Needs Replacing
- Reads Vacuum in 7 International Units
- Display Updates Every 1/2 Second
- Convenient Built in Hanger
- Low Battery Indicator
- Power Source: 3 AA Batteries (not included)
- Auto Shutoff



## VG60 ELECTRONIC VACUUM GAUGE

10 Segment Color Coded LED Readout Provides Fast Response of Vacuum Measurements

- Pocket Size - Only 5 1/2" x 1 3/4" x 1 1/2"
- Cleanable Sensor
- Single Switch Operation
- Built-in Hanger
- Soft Case Included



# VG640TL

## SUPCO® WIRELESS VACUUM GAUGE

- Remote Bluetooth® monitoring from up to 200 ft. away
- Revolutionary contaminant and oil resistant Lifetime Sensor
- Record and export the evacuation process to PDF/Excel/CSV
- Includes vacuum coupler and convenient magnetic holding strap



## VGC VACUUM GAUGE COUPLER FOR ALL VACUUM GAUGES

- 1/4" Female flare connections
- Brass construction

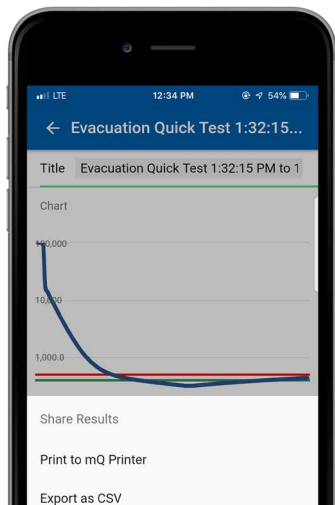

# DO MORE

USE THE POWER OF YOUR MOBILE DEVICE AND THE FREE SUPCO® TECHLINK™ APP TO EASILY DOCUMENT SYSTEM EVACUATIONS.



POWERED BY MEASUREQUICK™

# iDVM550 SUPCO®-REDFISH WIRELESS CLAMP METER

Measure AC Volts, AC Amps, system kW and the power factor. Use App-captured data to discuss system operating costs on jobs.



- Bluetooth® connectivity via BTLE (v4.0)
- Tested to IEC/EN61010 safety standards 600V CATIV and 1000V CATIII
- Advanced application diagnostics and guided tests
- Includes line splitter, test leads, carry bag, alligator clip and 9V battery

WORKS WITH  
measureQuick



SUPCO®  
TECHLINK™

POWERED BY MEASUREQUICK

## METER ACCESSORIES



iDVM510  
AC line splitter & voltage check

# iDVM510 SUPCO®-REDFISH WIRELESS MULTIMETER

Use the Supco® TechLink™ App for guided tests for capacitors, flame sensors, electrical circuits and systems.



- Bluetooth® connectivity via BTLE (v4.0)
- True RMS
- Ingress Protection - IP54 protects from dirt and splashed water
- 6,000 count (3-3/4 digit) resolution
- Advanced application diagnostics and guided tests
- Includes, test leads and 9V battery

WORKS WITH  
measureQuick

## CASE510

Soft-sided neoprene case for iDVM510 and accessories



iDVM333  
AC Current Transducer



### M500 LED MEGOHMMETER

The M500 provides fast and accurate measurements to verify the condition of the insulation.

- Zone scale to indicate insulation condition
- Measure insulation values up to 1000 megohms @ 500VAC
- Hand held
- Test leads store in case
- Operates on 2 C batteries (not included)
- Impact resistant
- Soft carrying case included



### MFD10 CAPACITOR TESTER

- Rubber grips & 12" magnetic leads
- Range: 0.001 $\mu$ F to 9999  $\mu$ F
- Auto-ranging
- Includes rugged carrying case and alligator clips

PATENTED VALVE GASKET APPLICATION PROVIDES 50 TIMES MORE SEALING AREA THAN COMPETITIVE "O" RING.



### BPV SERIES BULLET PIERCING VALVES

Part No.	O.D. Tubing Size	Packaging
BPV31*	1/4", 5/16", 3/8"	12/Box
BPV31D*	1/4", 5/16", 3/8"	48/Box
BPV21*	1/2", 5/8"	8/Box
BPV14	1/4"	12/Box
BPV56	5/16"	12/Box
BPV38	3/8"	12/Box
BPV34	3/4"	1/Box
BPV78	7/8"	1/Box

\*BPV21, BPV31 and BPV31D are furnished with adapters for indicated multiple applications

## START CAPACITOR OFFERING:

- Microfarad ratings from 21 up to 995 uF
- Voltage ratings from 110 up to 330 volt

## RUN CAPACITOR OFFERING:

- Over 250 ratings available
- Round and oval sizes
- Single and dual sections
- Voltage ratings - 370 or 440 volts

## WHAT WE DO

**SUPCO IS A CAPACITOR MANUFACTURER.** We make capacitors in over 250 ratings, available in 370 and 440 volts, in our own state-of-the-art facility. We have total control over the quality of the components that go into our capacitors and define the processes by which they are manufactured.

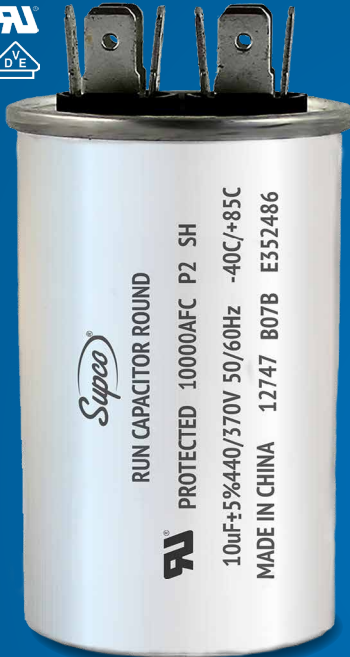

## RUN CAPACITORS

- HIGHER-QUALITY FOIL FOR INCREASED OPERATING TEMPERATURES -13°F TO 185°F (-25°C TO 85°C)
- LIFE TESTED AT 1.25 TIMES RATED VOLTAGE AT 185°F (85°C) FOR 1,500 HOURS
- DEEP VACUUM ASSEMBLY ELIMINATES MOISTURE
- 100% CAPACITANCE TESTED
- PROPER CAN SIZES FOR OPTIMAL PERFORMANCE & HEAT DISSIPATION
- NON-PCB BIODEGRADABLE SYNTHETIC OIL

## START CAPACITORS

- INDUSTRY STANDARD CASE SIZES
- MEETS CSA RS463-B STANDARD & IEC 60252-2 STANDARD
- NON-PCB BIODEGRADABLE SYNTHETIC OIL
- MOISTURE AND OIL RESISTANT CASES
- DUAL BLADE TERMINALS
- OPERATING TEMPERATURE -40°C TO 65°C





**LIGHT** meets **MIGHT**

# PORT-A-BLASTER® ZPB140

Weighing only 11 lbs., this rugged coil cleaning machine blasts dirt from evaporator and condenser coils using a patented, pressure activated pump.

## Product Features



Lightweight for easy carrying



Two pressure settings for mini-split indoor coils and outdoor coils



Includes durable quick-connect hoses, wand and trigger sprayer



On-board storage cabinet for all accessories



Durable construction and rugged housing



## Product Specifications

- Volts 120 VAC
- Weight 11 lbs
- Watts 80 W
- Size 12"H x 7"W x 11.5"L
- Flow Rate 0.25 GPM
- Handle 1.5"W
- Max. Pressure 140 PSI
- 1-Year Warranty





# INVENTED BY REAL TECHNICIANS MANUFACTURED BY SUPCO®

SUPCO has always recognized that the most innovative product ideas come directly from those who understand the challenges of the trade firsthand. Our exclusive product line - SUPCO® TradeFox™ - are innovative products that have been invented by real trade technicians to help make life in the HVACR field easier.

Through the SUPCO® TradeFox™ brand, we help technicians bring their inventions to life and to the market through our years of experience in engineering and manufacturing and our expansive distribution reach.

## SUPCO® TRADEFOX™ INVENTOR PROGRAM:

If you know a technician with an invention or product idea, they can send an email to [ideas@supcotradefox.com](mailto:ideas@supcotradefox.com) to find out more about our Inventor Program.

# RAIN OR SHINE

THIS IS THE UMBRELLA TECHS WANT



## ADJUSTABLE MAGNETIC UMBRELLA KIT

### MUKIT

- Includes umbrella & base
- 60" wide
- Waterproof umbrella with durable and flexible fiberglass ribs
- Base swivels and locks
- Heavy-duty magnet attaches securely to any metal housing.



## TECHNICIAN INVENTED. TECHNICIAN PROVEN.

The Magnetic Umbrella was designed by a real HVAC technician who zip-tied a speaker magnet to an umbrella to try to stay cool while working in the heat. Years later, he perfected and patented his design by figuring out how to make it lightweight, functional and cost effective.

# JONES VALVE® CONDENSATE CLEANOUT

JVI



## TECHNICIAN INVENTED. TECHNICIAN PROVEN.

The Jones® Valve was invented by a real HVAC technician who was looking for a way to permanently mount a multi-directional cleanout device on a condensate line so cleanouts would be faster and easier on service and maintenance calls.



- Most compact size on the market
- No cutting or repairing drain line
- Single Schrader allows for one hose hook-up
- 1/4" hose connection, 3/4" condensate line

# ATTIC PRO® UTILITY LIFT

ATPI



- Adjustable beam distance from 14" to 24"
- 20 ft. cable
- Lifts up to 250 lbs.



INCLUDES  
CARRYING  
CASE  
& STRAPS



## TECHNICIAN INVENTED. TECHNICIAN PROVEN.

The Attic PRO® was invented by a real HVAC technician who was also a fireman. As a one-man operation, he was looking for a way to help lift furnaces and air handlers up into attics. One day on a training exercise, he used a winch to pull a person out of a man-hole - and the Attic PRO idea was born.

# UNIVERSAL ECM TESTER

## ECMPRO

- 24" wire length
- Short circuit protection
- 24 VAC operating voltage & indicating light
- Convenient magnet on back of unit
- No batteries required



## TECHNICIAN INVENTED. TECHNICIAN PROVEN.

The ECMPRO was invented by an HVAC technician who was looking for a simple way to check if an Electronically Commutated Motor was good or bad in order to make a quicker diagnosis for the necessary repair.

# COOLPRESSOR

## CPPRO

### HIGH-POWERED MAGNETIC COMPRESSOR COOLER

- Uses high powered magnet
- Hands free
- Saves time
- Creates a powerful cascade of water
- No messy backsplash
- Attaches to garden hose



## TECHNICIAN INVENTED. TECHNICIAN PROVEN.

The Coolpressor was designed by a real HVAC technician who was looking for a more efficient way to quickly cool compressors on the job.





## MAGNETIC TEST LEADS

- Ideal for low voltage, 30V
- Powerful magnets
- 20" wire length

YELLOW - MAGTYL  
 BLUE - MAG1BL  
 BLACK - MAG1BK  
 GREEN - MAG1GR  
 RED - MAG1RD

## RETRACTABLE MAGNETIC JUMPER

### MAGTRACT

- 20" leads
- For use up to 30V / 5A
- For diagnostic use only

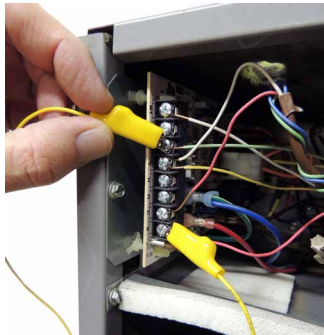

## HYBRID JUMPER

### HYB1YL

- 20" lead
- Used for low voltage troubleshooting
- For use up to 30 volts / 5 amps
- Magnetic tips & alligator clips



## FUSE TESTING SUPER KIT

### BRKPRO

- Six piece kit
- (1) Standard Blade to 1/4" Fuse Adapter
- (1) Standard Blade to 5mm Fuse Adapter
- (1) Standard Blade to 4.5mm Fuse Adapter
- (1) Supco® Fuse Pro 3 AMP Tester with Light
- (1) Supco® Fuse Pro 5 AMP Tester with Light
- Auxiliary Wire Harness

## FUSE PRO BREAKERS

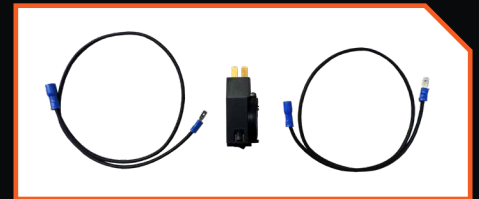

- Two available sizes: 3 or 5 amp
- Plugs directly into PC boards
- Built in light for dark control board locations
- Eliminates wasted fuses

Supco® Part No.	Description
BRK3	3 Amp Breaker
BRK5	5 Amp Breaker

## ROUND FUSES. SPADE FUSES.

# ONE KIT GETS THE JOB DONE

## BEARING BUSTER



- Reduces bearing replacement time
- Slide hammer action
- Breaks bearing loose from shaft and bracket



Supco® Part No.	Description
BB34	for 3/4" Shafts
BB10	for 1" Shafts
BB114	for 1-1/4" Shafts



## MANIFOLD GAUGE HANGER

### HVACSTRAP

- Decreases work time - put gauges where you want them
- Safe - keeps high voltage away from gauges
- Vinyl coated magnet will not scratch or damage unit
- Increases readability and convenience



# REFRIGERANT SAFETY LOCKING CAPS

Supco® Part No.	Description	
SFL1402	2 Pack	1/4"
SFL1410	10 Pack	1/4"
SFL1450	50 Pack	1/4"
SFL51602	2 Pack	5/16"
SFL51610	10 Pack	5/16"
SFL51650	50 Pack	5/16"

USES A STANDARD  
3/16" HEX KEY  
FOR REMOVAL

RESISTS FAT, GREASE,  
OILS AND SOLVENTS

COMPATIBLE WITH R717, R12,  
R22, R134A, R404A, R410A  
AND OTHER REFRIGERANTS.

NO SPECIAL TOOLS REQUIRED

CODE COMPLIANT FOR  
TAMPER RESISTANCE

UV RESISTANT  
THERMOPLASTIC

PATENTED CAM ACTION  
CAP THAT EASILY  
TIGHTENS BY HAND



## PROOF IN PERFORMANCE

RAKE-LIKE HEAD HELPS ELIMINATE AIRBORNE DUST AND CLEAN MORE EFFECTIVELY

## COIL CLEANING BRUSH

CCB100



- Adjustable brush head pivots up to 120°
- Patented stiffness adjustment slide
- Two tempered stainless steel cleaning heads built into a single unit
- Handles extends to 4 ft.

## FURNACE PRO (6 PACK)

FPRO100



- Holds in door switch for troubleshooting furnaces, air handlers, etc.
- Hands-free



## FLAME SENSOR CLEANER

FSC10

- Easily cleans sensor
- Prevents false starts
- Convenient key ring

FP18



## FILTER PULLERS

FP48

- Makes getting hard to reach filters easy
- FP18: 18" extension
- FP48: 48" extension



# DITCH THE SCREWDRIVERS

DISCHARGE CAPACITORS SAFELY

## CAP DISCHARGE PEN CAPDIS



- LED Indicator When Capacitor is Charged
- Standard Magnetic Connector or Alligator Clip Adapter



## CAPACITOR SHELF WITH MAGNET CSWM1

- Capacitor Shelf With High Strength Magnet



## 4-PACK CAPACITOR SHELF CSX4



- Capacitor Shelf (4 Pack)
- Includes Cable Ties & Mounting Screws

## FLEXIBLE VALVE CORE TOOL

### FVCT4

- 4 1/2 inches in length
- Flexible to over 120° angle
- CNC finished



## FLEXIBLE VALVE CORE TOOL W/ STORAGE

### FVCT4PLUS

- 4 7/8 inches in length
- Flexible to over 120° angle
- CNC finished
- Comes with 3 valve cores



## VALVE CORE GRIPPER TOOL W/ GASKET INSTALLER

### VCCT3

- 3.5 inches in length
- Integrated key ring



# PRODUCTS

We've given the SUPCO® TradeFox™ seal of approval to the following innovative technician-designed products. These products are distributed by SUPCO® to HVACR supply houses nationwide.



## THE DAUBER STOPPER™ A/C DRAIN LINE GUARD

### DS1

- Four-bolt flange or pipe reducer for easy installation
- Provides finished appearance to home
- Durable ABS material
- UV protection with 10 year warranty
- Made in the USA

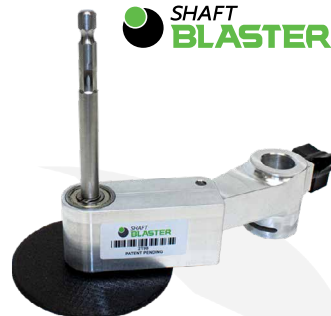

## THE SHAFT BLASTER™ MOTOR SHAFT CUTTING TOOL

### SB100

- Precision machined aluminum housing
- Aluminum oxide grain cutting wheel for aggressive cutting action
- Stainless steel quick change arbor
- Tightens to motor shaft with thumb screw



## PVC FLUE CAP

### ECAP321

- Resistant to heat, cold, precipitation or UV radiation
- Protects furnace motor and interior from damaging moisture, debris and pests
- Precisely and quickly fits 1.5", 2" and 3" PVC pipe



# WHEN IAQ IS CRUCIAL, WE HAVE SOLUTIONS.

Universal Solutions® Clear Blue® line of residential UV systems are distributed exclusively by SUPCO. These products are the smart answer to reduce bacteria, viruses and mold in the air and on the HVAC coil.



**5-YEAR**  
BALLAST WARRANTY  
**1-YEAR**  
UV LAMP WARRANTY



	ADVANCED	MASTER	PCO
SUPCO® PART NO.:	UUV-CBA	UUV-CBM	UUV-CBM-PCO
VOLTAGE	18-32V AC or DC	24VAC & 110 VAC	24VAC & 110 VAC
16" UV GERMICIDAL COIL CLEANER	✓	✓	✓
IMPROVE ENERGY EFFICIENCY	✓	✓	✓
DESTROY MOLD & ODORS	✓	✓	✓
VARIOUS MOUNTING SCENARIOS	✓	✓	✓
OVER/UNDER VOLTAGE INDICATOR	✓	✓	✓
LCD W/ REAL TIME STATUS		✓	✓
COUNTDOWN PURIFIER ANIMATION		✓	✓
CALL-BACK INDICATOR		✓	✓
PHOTOCATALYTIC OXIDATION			✓
CAPTURES VOLATILE ORGANIC COMPOUNDS			✓

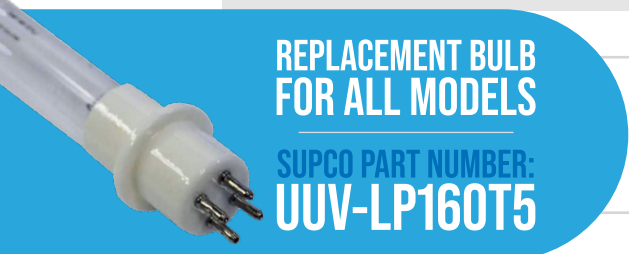

**REPLACEMENT BULB FOR ALL MODELS**  
SUPCO PART NUMBER: **UUV-LP160T5**

## CAN REPLACE OTHER BRANDS

UV light bulbs should be replaced annually for maximum effectiveness.

## IAQ1040 FAN CYCLE TIMER

Maximize the efficacy of IAQ accessories such as air filters, air purifiers, odor neutralizers, or other air treatment products that may be connected to that HVAC/heating System during "in-between" seasons when there is no call for heating and/or cooling.

- The IAQ1040 is set to intermittently operate a central HVAC or heating furnace indoor blower/ fan between 10 and 40 minutes every hour of every day
- Helps improve the performance of IAQ accessories that are filtering and cleaning the air
- Perfect for older systems where thermostats do not have an option to cycle the fan intermittently
- Ideal for areas of high humidity - the IAQ1040 provides an additional fan on delay after the thermostat shuts the AC off to prevent bringing excessive moisture from the water condensation on the AC coil in to the room



**AVAILABLE MARCH 2021**



## MINI-SPLIT CONDENSATE PUMPS



### DE05LUB100 - 120 V DE05LUB110 - 240 V **FLOWWATCH® 2**

- 2-year warranty
- Can use with optional mounting kit



### CCKFX2010 **MOUNTING KIT**

- For Siccom® mini split pumps only



## MINI-SPLIT RUN CAPACITORS



Part No.	Description
RC1X450	1MFD 450V
RC1.5X450	1.5MFD 450V
RC2X450	2MFD 450V
RC2.5X450	2MFD 450V
RC3X450	3MFD 450V
RC3.5X450	3.5MFD 450V
RC4X450	4MFD 450V
RC4.5X450	4.5MFD 450V
RC5X450	5MFD 450V
RC6X450	6MFD 450V
RC7.5X450	7.5MFD 450V
RC8X450	8MFD 450V
RC10X450	10MFD 450V
RC12.5X450	12.5MFD 450V
RC15X450	15MFD 450V
RC20X450	20MFD 450V

## MINI-SPLIT BRACKETS

Part No.	Size	Max Capacity
MB100	14.5" X 17.75"	240 lb.
MB200	15.5" X 17.75"	240 lb.
MB300	16.5" X 21.63"	265 lb.
MB400	16.5" X 21.63"	240 lb.
MB500	19.25" X 21.63"	265 lb.
MB600	15.35" X 17"	330 lb.
MB700	18" X 18"	440 lb.

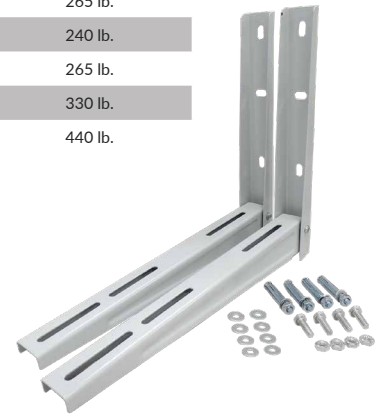

## ZCA24 MINI-SPLIT CATCH ALL™

- Fully adjustable from 47" x 25" for wall unit, to 47" x 47" for ceiling units
- Durable construction and material for multi-use
- Includes storage and carry bag



## ZMF56 MINI-FIT™ FLEXIBLE MINI-SPLIT ADAPTER

- Adapts 1/4" hose fitting to 5/16" Mini-Split R-410A fitting
- Eases access to service ports in tight fitting ductless condensing unit applications
- High Quality Brass Design with high pressure hose
- Rated for use with all refrigerants



## RESIDENTIAL / LIGHT COMMERCIAL NEGATIVE PRESSURE WATERLESS TRAP FCN

- Eliminates the geyser effect that is caused when the standard P-Trap dries out and condensate begins to form
- Requires less than half the height of a standard P-Trap.
- Operates dry except when condensate is being produced
- Will not freeze
- No sludge build-up in bottom of trap
- Easily comes apart for cleaning



RLC051



RLC051C

## RESIDENTIAL WATERLESS TRAP

- Prevents air from entering or escaping
- No more "dry-trap"
- Reduces trap height by up to 60%
- Eliminates sludge build-up

## POSITIVE & NEGATIVE PRESSURE WATERLESS TRAPS

Vertical	Horizontal	Description
PPC34V	NPC34H	3/4", CLEAR
PPC1V	NPC1H	1", CLEAR
PPC114V	NPC114H	1 1/4", CLEAR
PPC112V	NPC112H	1 1/2", CLEAR
PPW34V	NPW34H	3/4", WHITE
PPW1V	NPW1H	1", WHITE
PPW114V	NPW114H	1 1/4", WHITE
PPW112V	NPW112H	1 1/2", WHITE

- Vertical or Horizontal mount
- Allows condensate to drain from HVAC equipment
- Prevents air from entering or escaping the system
- Operates wet or dry
- Schedule 40 Clear PVC or Schedule 40 White PVC

## HVAC AIR-TRAP™ WATERLESS TRAPS

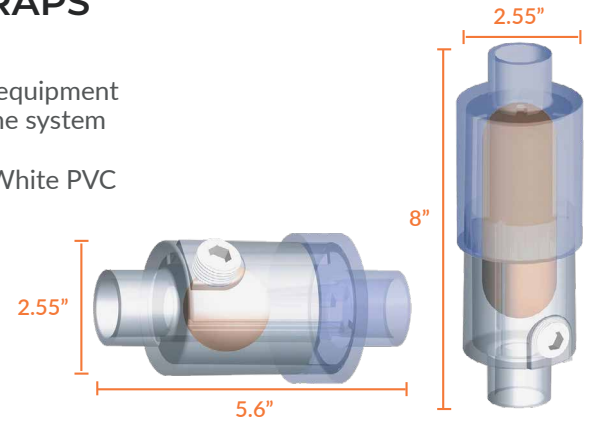

## CONDENSATE DRAIN HEATERS

Part No.	Volts	Watts	Size	Leads
SH500	120	11	9"	18"
SH502	120	15	13"	18"
SH503	240	15	13"	18"
SH504	120	25	21"	18"
SH505	240	25	21"	18"



## DRAIN PLUS CONDENSATE DRAIN DP34

- Eliminates "dry-trap" Syndrome
- Fits 3/4" drain lines



## UNIVERSAL DRAIN HEATER

Part No.	Volts	Watts
SH250	120	3

## CONDENSATE PUMPS



High quality, affordable pumps that incorporate audible alarm and an overflow switch that can be used to shut down the system.

### SPCPT15 & SPCP230

- Available in with 115 or 230 volt
- 22 ft. of lift
- 3 inlet holes



## CONDENSATE PUMP DRAIN TUBING

Part No.	Size
CPT3825	3/8 x 25'
CPT38100	3/8 x 100'

## JV1

### JONES VALVE® CONDENSATE CLEANOUT

- Most compact size on the market
- No cutting or repairing drain line
- Single Schrader allows for one hose hook-up
- 1/4" hose connection, 3/4" condensate line

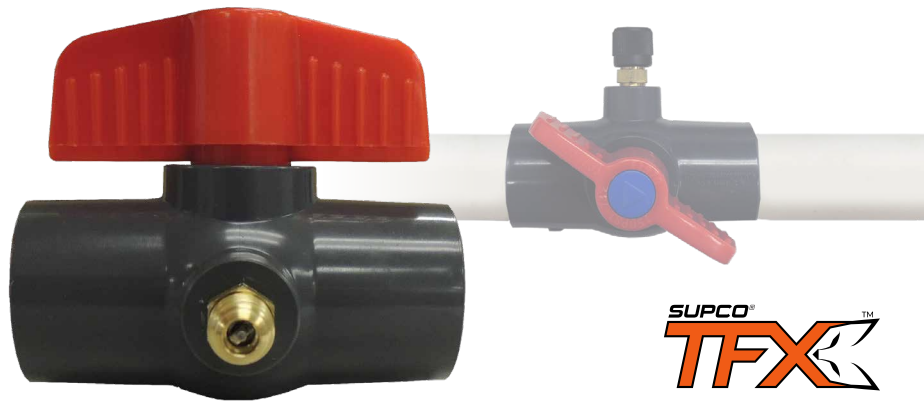

## WGW24

### ELECTRONIC WATER OVERFLOW ALARM

- Shuts down system in the event of water leakage
- Use in conjunction with condensate pump as an additional safety mechanism
- LED indicators: Green: normal operation; Red: alarm condition
- Hermetically sealed, waterproof housing



## WG1

### WATER GUARD

- Powered by 9V battery (not included)
- Low battery indicator
- Alarms up to 72 hours
- Floating case
- Compact design, fits around appliances
- Powerful 90dB alarm
- Responds to direct contact with water



## DLG-1

### CONDENSATE DRAIN LINE GUN

Easy to carry drain line gun makes clearing clogged drain lines a breeze. Just load a cartridge, pull the trigger, and watch the line clear. CO2 cartridges deliver 800 PSI of oil free air to clear the line.

- Flexible Hose
- Rubber adaptor for quick sealed connection



## CO2-12

### CO2 CARTRIDGES

- Standard 16 gm
  - Smooth cartridge
  - Food grade CO2
  - 12 per pack
  - Compact
  - Portable
  - Also Available: 12 pack Threaded Cartridges
- ITEM ID: CO2-12T



### SLIMEOUT® CONDENSATE PAN CONDITIONING TABS

Part No.	Description	Tablets/Jar
SO100	Slime Out	100
ST200	Slime Tab	200



## THE TECHNICIAN-INVENTED "NO TOOL" REFRIGERATION SAFETY LOCKING CAPS



- Compatible with R717, R12, R22, R134a, R404A, R410A and other refrigerants.
- No special tools required. Simply tighten by hand.

 **MEETS IRC M1411.6 AND IMC1101.10 FOR TAMPER RESISTANCE**

Part No.	Description
SFL1402	Safety Locking Cap 1/4" set of 2
SFL1410	Safety Locking Cap 1/4" set of 10
SFL1450	Safety Locking Cap 1/4" set of 50
SFL51602	Safety Locking Cap 5/16" set of 2
SFL51610	Safety Locking Cap 5/16" set of 10
SFL51650	Safety Locking Cap 5/16" set of 50



WITH OVER 140 SKUS, WE OFFER A COMPLETE ACCESS FITTING LINE  
**MANUFACTURED IN OUR OWN FACILITIES.**

### CAPS, O-RINGS, LOCK NUTS, VALVE CORES, SEALS & REFRIGERANT LOCKING CAPS



### SADDLE VALVES



### VALVES



### 1/4" ACCESS FITTINGS WITH 2" LONG COPPER TUBE



### TEE FITTINGS

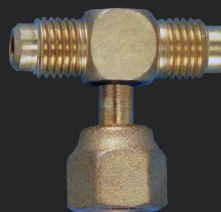

### ACCESS BODIES

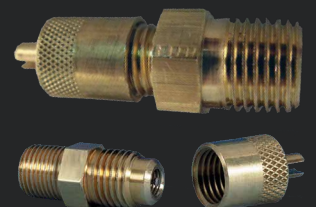

### COPPER TEE FITTINGS



### CONNECTORS



### TOOLS



VISIT [SUPCO.COM](http://SUPCO.COM) AND SEARCH "ACCESS" IN THE SEARCH BAR



## DEFINITE PURPOSE CONTACTORS

- Silver cadmium oxide contacts
- Compact universal design and interchangeable mounting plate allow for easy replacement of most brands.
- Space saving dimensions
- Economically priced



### 1.5 POLE

Part No.	Full Load Amps	Coil Voltage
DP25241	25	24
DP251201	25	120
DP252401	25	240
DP30241	30	24
DP301201	30	120
DP302401	30	240

### 2 POLE

Part No.	Full Load Amps	Coil Voltage
DP20242	20	24
DP201202	20	120
DP202402	20	240
DP25242	25	24
DP251202	25	120
DP252402	25	240
DP30242	30	24
DP301202	30	120
DP302402	30	240
DP40242	40	24
DP401202	40	120
DP402402	40	240

### 3 POLE

Part No.	Full Load Amps	Coil Voltage
DP25243	25	24
DP251203	25	120
DP252403	25	240
DP254803	25	480
DP30243	30	24
DP301203	30	120
DP302403	30	240
DP304803	30	480
DP40243	40	24
DP401203	40	120
DP402403	40	240
DP404803	40	480
DP50243	50	24
DP501203	50	120
DP502403	50	240
DP60243	60	24
DP601203	60	120
DP602403	60	240
DP75243	75	24
DP751203	75	120
DP752403	75	240
DP90243	90	24
DP901203	90	120
DP902403	90	240

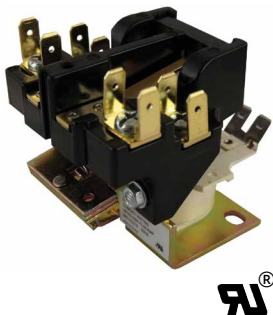

### 2 POLE MAGNETIC LINE CONTACTOR SMC11

- Non-Positional
- Replaces Mars® 18001 (exact) and Honeywell® R850B1146, Packard® C18001
- Includes 4 Terminals and 4 Screws
- UL® File Number E328772



### 3 POLE AUXILIARY SWITCH FOR CONTACTORS

Add additional load switching capability for low load accessories.

Part No.	Contactors	Current	Switch Action
DPAUX1	25A to 40A	10A at 300 VAC	SPDT (1)
DPAUX2	25A to 40A	10A at 300 VAC	SPDT (2)
DPAUX3	25A to 40A	10A at 600 VAC	(1) SPNO, (1) SPNC
DPAUX4	25A to 40A	10A at 600 VAC	SPNO (2)
DPAUX5	50A to 60A	10A at 300 VAC	SPDT (1)
DPAUX6	75A to 90A	10A at 300 VAC	SPDT (2)

References to original equipment manufacturers' names, models, trademarks and part numbers are used for identification purposes only and SUPCO® replacement products are not in any way affiliated, endorsed or sponsored by such original equipment manufacturers.

# RECLAIM YOUR DOMAIN.

ELIMINATE EXCESSIVE TRUCK STOCK WITH OUR WIRE-TO-WIRE UNIVERSAL POTENTIAL RELAYS

**DROP-IN**

**OR**

**DIAL-IN**

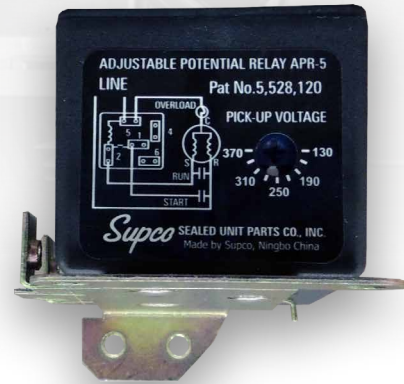

**UNIVERSAL POTENTIAL RELAY**  
**SUPR**

**ADJUSTABLE POTENTIAL RELAY**  
**APR5**

Time Function	<b>RELAY TYPE</b>	Adjustable Voltage Sensing
Electronic Potential Relay (EPR)	<b>RELAY TECHNOLOGY</b>	Electronic Potential Relay (EPR)
1.0 to 1.5 seconds	<b>SAFETY TIMEOUT</b>	1.0 to 1.5 seconds
110 - 270 VAC	<b>OPERATING VOLTAGE</b>	110 - 270 VAC
30 AMPS	<b>AMPERAGE</b>	30 AMPS
Single-phase up to 5 hp	<b>MOTOR POWER RATING</b>	Single-phase up to 5 hp
Screw-on or push-on	<b>TERMINALS</b>	Screw-on or push-on
Universal Mounting Bracket	<b>MOUNTING</b>	Universal Mounting Bracket
1.75"W X 2.25" L X 1.50" H	<b>DIMENSIONS</b>	1.75"W X 2.25" L X 1.50" H

## 90XX SERIES POTENTIAL RELAYS

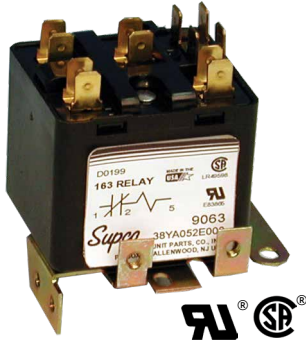

Part No.	Continuous Coil Voltage	Pick-Up Min.	Pick-Up Max.	Drop Max
9063	168	140	153	45
9064	395	242	272	140
9065	332	168	182	90
9066	395	204	233	130
9067	420	280	310	121
9068	502	314	342	135
9069	338	180	195	105
9070	332	285	305	85
9071	420	223	259	121

- Voltage sensitive relay
- Instant re-start
- Safety time delay
- Use with any size suitable start capacitor

## 903X SERIES GENERAL PURPOSE SWITCHING RELAYS DOUBLE POLE DOUBLE THROW



Part No.	Coil Voltage	FLA 120V	FLA 208V	FLA 240V	FLA 277V	HP	Essex®/RBM®	Honeywell®
90340	24	13.8	7.6	6.9	6	3/4	90-340	R8222D1014
90341	120	13.8	7.6	6.9	6	3/4	90-341	R4222D1013
90342	208/240	13.8	7.6	6.9	6	3/4	90-342	R4222N1021

## FAN RELAYS



Supco® Part No.	Type	FLA 250V	LRA 250V	Coil VAC
90290	SPST	8	18	24V
90291	SPST	8	25	120V
90292	SPST	8	25	240V
90293	SPDT	8	18	24V
90294	SPDT	8	25	120V
90295	SPDT	8	25	240V

Supco® Part No.	Type	FLA 125V	LRA 125V	FLA 250V	LRA 250V	Coil VAC
90370	SPDT	12	60	8	48	24V
90372	SPDT	14	84	8	48	120V
90374	SPDT	14	84	8	48	240V
90380	NO/NC	12	60	8	48	24V
90382	NO/NC	12	60	8	48	120V
90384	NO/NC	12	60	8	48	240V

- Single or Double Poles
- Meets All Safety Requirements

## TIME DELAY RELAYS

### TD60 SERIES DELAY ON MAKE TIMERS (DOM)



- 6 sec. to 8 min adjustable
- 12/case

TD68 | TD69

### TD70 SERIES DELAY ON BREAK TIMERS (DOB)



- 6 sec. to 5 min adjustable
- 12/case

TD72 | TD73

### SHORT CYCLE PROTECTOR



Adjustable time delay on make relay

**TDP269**

# CONTROLS - THERMOSTATS

## THERMODISC®

### ML SERIES - DEFROST THERMOSTATS



Part No.	Open °F	Close °F	Diff. °F	Mars®	Uniline®
ML37*	37	47	10		
ML45	45	20	25	33008	31-001 17001
ML50	50	20	30	33009	31-002 17003
ML55	55	20	35	33010	31-003 17005
ML60	60	20	40	33011	31-004 17007
ML70	70	20	50	33012	31-005 17009
ML80	80	50	30	33020	31-006 17011

\*Closes on rise

### SLT SERIES



Part No.	Open °F	Close °F	Diff. °F
SLT45	45	22	23
SLT50	50	10	40
SLT55	55	25	30
SLT60	60	30	30

- Metal case with waterproof epoxy potting
- Heavy Duty Rating 10 Amps @ 120 V / 5 Amps @ 240 V
- Switching is SPST
- Uses SL249 tube clip

### FIRE STAT SMRL130



- Opens at 130°F
- Close when temperature differential is reached



### ECONOMICAL FREEZE PROTECTION CONTROL Protects air conditioning evaporator coils from freezing.

#### SFPC

- Opens 35°F / Close 50°F
- Fits 7/8" O.D. tubing
- Rated 10A@120V, 5A @ 240V
- 12" leads

### SL SERIES EXACT REPLACEMENT REFRIGERATION THERMOSTATS

- 2-wire Heater Limit
- SPST
- Resistive Amps: 25
- Volts AC: 120/240



Part No.	Open °F	Close °F	Mount	Replaces
SL5708	75	40	Surface	Bohn®, Larkin®, Chandler®, Climate Control® 5708L & 4752C



Part No.	Open °F	Close °F	Mount	Replaces
SL5709	55	35	Surface	Bohn®, Larkin®, Chandler®, Climate Control® 5709L & 4751C

- Surface Mount
- 3-wire Defrost Terminator and Fan Control (Exact Replacement)
- SPDT
- Resistive Amps: 25
- Volts AC: 120/240



Part No.	Open °F	Close °F	Mount	Replaces
SL79002	55	35	Tube	Russell® 103079002
SL79005	65	30	Surface	Russell® 103079005

- 3-wire Defrost Terminator and Fan Control (Exact Replacement)
- SPDT
- Resistive Amps: 25
- Volts AC: 120/240



**UNIVERSAL THERMOSTAT GUARD | BTG-UN**  
**REPLACES OVER 100 THERMOSTAT GUARDS**

1 YEAR LIMITED WARRANTY



**FEATURES & SPECIFICATIONS**

- ✓ Fits Thermostats Up to 7.3" W x 5.25" H x 1.8" D
- ✓ Tamper Resistant Lock
- ✓ Durable Clear Plastic Protects Against Thermostat Damage
- ✓ Vented For Proper Air Flow
- ✓ For New and Existing Thermostat Applications
- ✓ Slim Contemporary Style



**THERMOSTAT GUARDS**

Part No.	Dimensions
BTG-UN	7.3" W x 5.25" H x 1.8"
BTG-UM	8 1/4" x 5 3/8" x 3 1/2"
BTG-UWM	6 3/4" x 4 1/2" x 3 9/16"
BTG-54VL	6 3/4" x 4 1/4" x 3 1/8"
BTG-54VLW	6" x 3 3/4" x 3 1/8"

**AFFORDABLE THERMOSTATS DESIGNED WITH CONTRACTORS IN MIND**



A Division Of SUPCO®

**WALL THERMOSTATS**

- 2 Heat / 2 Cool Heat Pump Systems
- System Powered w/ Battery Backup

**MECHANICAL THERMOSTAT**



43004A

43005A

- Heat / Cool
- Snap Action Switching
- Mercury Free

**DIGITAL THERMOSTAT**



43054

- Non-Programmable
- Filter Change Indicator
- Indiglo Backlight

**5/2 DAY PROGRAMMABLE THERMOSTAT**



43154

- Pre-Programmable
- 4 Periods Per Day
- Indiglo Backlight

## S8000 SERIES COMMERCIAL DEFROST CONTROLS



**Part No.**  
X3596 Dial Pins 5 Pins Per Pack



Part No.	Volts (AC)	Paragon®
S804100	120	8041-00
S804120	240	8041-20
S804500	120	8045-00
S804520	240	8045-20
S804521	208/240	8045-21
S814100	120	8141-00
S814120	240	8141-20
S814500	120	8145-00
S814520	240	8145-20

## COMMERCIAL DEFROST MECHANISM

A SUPCO® ORIGINAL INNOVATION. This timer mechanism SNAPS into the existing case as an exact drop-in replacement. These electro-mechanical controls are used on many different types of commercial refrigeration equipment, including walk in boxes, reach in boxes, refrigerated cases and condensing units.

Part No.	Can Replace - Exact Drop-In	Volts
M814500	Paragon® 8145-00, SUPCO® S814500	120
M814520	Paragon® 8145-20, SUPCO® S814520	208/240

6 PER CASE

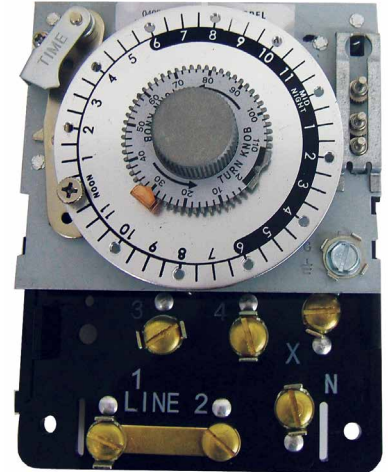

## UNIVERSAL ELECTRONIC DEFROST TIMERS

The EDT Series defrost timers utilize adjustable timing and industry standard wiring to replace most domestic and many commercial defrost timers.

Part No.	Description	Voltage	Max Compressor Rating	Max Resistive Load (Amps)
EDT10	Electronic Defrost Timer	115 VAC	1/3 HP	10
EDT11	Electronic Defrost Timer	115 VAC	3/4 HP	15
EDT20	Electronic Defrost Timer	208/240 VAC	3/4 HP	5
EDT21	Electronic Defrost Timer	208/240 VAC	3/4 HP	15
UET120	Universal Electronic Timer	120 VAC	1/2 HP	10
UET240	Universal Electronic Timer	120 VAC	1/2 HP	5

## GENERAL PURPOSE TIMER SWITCHES

Part No.	Volts	Switch	Paragon®	Intermatic®	Precision®
ST101	120	SPST	4001-00	T101	CD101
ST102	240	SPST	4002-71	T102	CD102
ST103	120	DPST	4003-00	T103	CD103
ST104	240	DPST	4004-71	T103	CD104
STPIN		Tripper pair		2/bag	



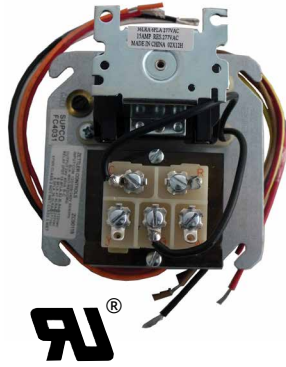

## UNIVERSAL FAN CENTERS

Part No.	VA	Primary VAC	Secondary VAC	HP	Jard®	Mars®	Steveco®
FC4011	40	120	24	3/4	4011FC	24013	90-113
FC4031	40	120/208/240	24	3/4	4031FC	24010	90-130

- DPDT plug-in style relay (90340)
- 40 VA transformer
- Mounts directly to 4" x 4" electrical box
- Color coded wiring for easy installation
- Universal FC4031 includes multi-tap primary voltages for all applications, reduces inventory

## UNIVERSAL TRANSFORMER

Part No.	VA	Primary VAC	Secondary VAC	H	W	D	MW
T45	48	120/208/240	2.5, 8, 12, 16 & 24	2 1/16"	3 1/4"	2 3/4"	2 13/16"

- 50/60 Hz.
- Enclosed frame - plate, foot or knock-out mount
- Includes 4"x4" mounting plate, wire nuts, 1/2" conduit & 8" leads

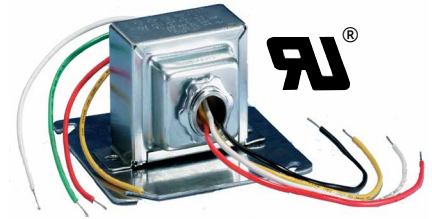

## CONTROL TRANSFORMERS

### Foot Mount Transformers Specifications

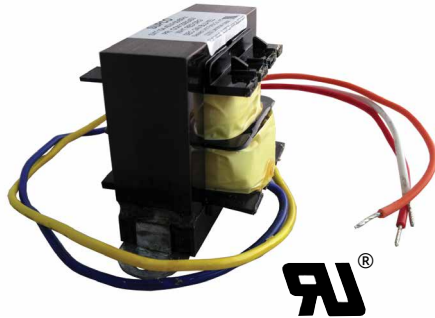

Part No.	Primary V	Secondary VAC	Output VA	Breaker/Fuse	Agency
SXT100R	120/208/240/480	24	100	Breaker	UR®
SXT101	120/208/240	2.5/12/24	40	Fuse	UR®
SXT105	120/208/240	24	40	No	UR®
SXT114	120/208/240	24	20	No	UR® CSA®
SXT115*	120/208/240	24	40	No	UR® CSA®
SXT116	120	24	40	No	UR® CSA®
SXT79R	120/208/240/480	24	75	Breaker	UR®

\*Includes Metal Shroud

## MULTI-MOUNT TRANSFORMERS SPECIFICATIONS

Part No.	Primary V	Secondary VAC	Output VA	Breaker/Fuse
SXT106	120/208/240	24	40	No
SXT111	120/208/240	2.5/12/24	40	Fuse
SXT113	208/240	40	40	No
SXT148	120/208/240	2.5/12/24	48	No
SXT150	120/208/240	24	50	Fuse

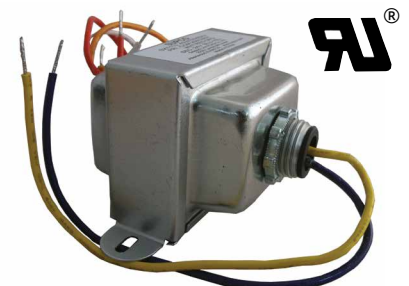

## DIRECT REPLACEMENT MOTORS



### SM1127 UNIVERSAL 3.3" EVAPORATOR FAN MOTOR

- Open Ventilation; Reversible
- Sleeve Bearing
- 115/230V; 1150 RPM
- 1.1/6 AMPS

CAN REPLACE 100 OEMS



### SM4753 DRAFT INDUCER MOTOR

- 115V / 1.8 FLA
- Overload protection
- Single speed - 3300 RPM
- Cable with connectors and plastic fan blade included

CAN REPLACE CARRIER® HC21ZE117 & MANY OTHERS



### SM6700B MOTOR KIT ASSEMBLY

- 120V / 3000RPM
- 3/16" X 1-1/4" Shaft
- 5/8" Stack
- Replaces Acme Miami® 700
- OEM Replacement for Bohn®, Heatcraft®, Uppco®, Singer®, GE® 33 Series
- Kit Includes Reversible Motor, Three Fan Blades (FB402, FB455 & FB550), Hardware Kit and Instructions

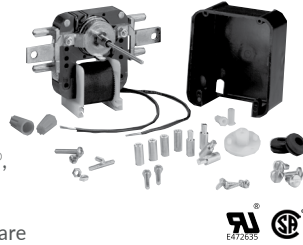

### SM999 UNIVERSAL EVAPORATOR FAN MOTOR KIT

- 120 VAC, 3000 RPM, 1/200 HP, .31 Amp Impedance Protected
- Replaces over 450 different evaporator type motors
- Pre-fastened multi fit, break off mounting bracket
- Break off 2" motor shaft with breakaways at 1/2" and 1 1/2"
- Includes all mounting accessories and hardware
- Reversible rotation
- Single speed
- Shaft diameter 1/8"

## UNIT BEARING WATT MOTORS ALUMINUM



Part No.	Watts	Volts	Amps	Rotation	Shaft Diameter	Shaft Length
SM5109	2	120	0.28	CWOSE	1/4" Threaded	1/2"
SM5211	4	120	0.36	CWOSE	1/4" Threaded	1/2"
SM5212	4	120	0.32	CCWOSE	1/4" Threaded	1/2"
SM5221	4	240	0.16	CWOSE	1/4" Threaded	1/2"
SM5222	4	240	0.16	CCWOSE	1/4" Threaded	1/2"
SM5311	6	120	0.52	CWOSE	1/4" Threaded	1/2"
SM5312	6	120	0.43	CCWOSE	1/4" Threaded	1/2"
SM5411	9	120	0.60	CWOSE	1/4" Threaded	1/2"
SM5412	9	120	0.64	CCWOSE	1/4" Threaded	1/2"
SM5421	9	240	0.32	CWOSE	1/4" Threaded	1/2"
SM5422	9	240	0.32	CCWOSE	1/4" Threaded	1/2"
SM5811	16	120	0.92	CWOSE	1/4" Threaded	1/2"
SM5812	16	120	0.92	CCWOSE	1/4" Threaded	1/2"
SM5821	16	240	0.48	CWOSE	1/4" Threaded	1/2"
SM5822	16	240	0.48	CCWOSE	1/4" Threaded	1/2"

## CAST IRON



Part No.	Watts	Volts	Amps	Rotation	Shaft Diameter	Shaft Length
SM351	35	120	1.4	CWOSE	1/4" Threaded	1/2"
SM352	35	120	1.4	CCWOSE	1/4" Threaded	1/2"
SM353	35	240	0.7	CWOSE	1/4" Threaded	1/2"
SM354	35	240	0.7	CCWOSE	1/4" Threaded	1/2"
SM501	50	120	1.7	CWOSE	3/8" Smooth Flatted	1/2"
SM502	50	120	1.7	CCWOSE	3/8" Smooth Flatted	1/2"
SM503	50	240	0.85	CWOSE	3/8" Smooth Flatted	1/2"
SM504	50	240	0.85	CCWOSE	3/8" Smooth Flatted	1/2"

References to original equipment manufacturers' names, models, trademarks and part numbers are used for identification purposes only and SUPCO® replacement products are not in any way affiliated, endorsed or sponsored by such original equipment manufacturers.



- SM675 is Thermal Protected
- SM675 Includes Fan Blade FB550 Only
- SM670, SM672, SM673 and SM690C Include Fan Blades FB402 and FB550
- Motor Kits Include Complete Hardware and Mounting Kits

## SM600 SERIES EXACT REPLACEMENT & UTILITY MOTOR KITS

Part No.	Type	Volts AC	RPM	Shaft (in.)	Stack (in.)	Rotation (Reversible)
SM670	Sleeve	120	3000	3/16" x 1 1/4"	5/8"	CW/CCW
SM671	Sleeve	120	3000	3/16" x 1 1/4"	5/8"	CW/CCW
SM672	Sleeve	240	3000	3/16" x 1 1/4"	5/8"	CW/CCW
SM673	Sleeve	120	3000/1550	3/16" x 1 1/4"	5/8"	CW/CCW
SM675	Sleeve	120/240	3000	3/16" x 2 3/8"	1"	CW/CCW
SM690C	Sleeve	120	3000	3/16" x 1 1/4"	5/8"	CW/CCW

## FAN HOOD MOTORS

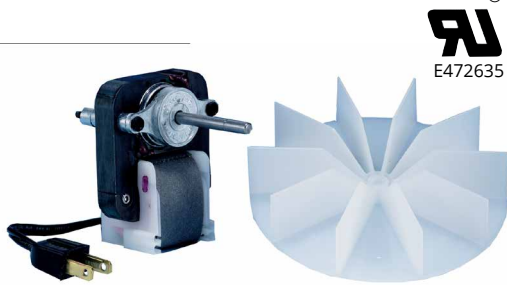

CAN REPLACE NUTONE® RANGE HOOD VENTILATORS

Part No.	Volts	Speeds	RPM	Rotation	Shaft Diameter	Shaft Length
SM550	120	1	3000	CCW	7/32" Flat	1 3/4"
SM550P2*	120	1	3000	CCW	7/32" Flat	1 3/4"
SM551	120	2	3000/1640	CW	7/32" Flat	1 7/16"
SM552	120	1	3000	CCW	7/32" Flat	1 1/4"
SM553	120	1	3000	CCW	7/32" Flat	1 3/4"
SM554	120	2	3000/1500	CCW	7/32" Flat	1 7/16"
SM555	120	1	3000	CCW	7/32" Flat	2 3/8"

\*2 Pack



## EXACT REPLACEMENT PLASTIC IMPELLERS

Part No.	Replaces	Blade O.D.	Hole I.D.
SB001	Nutone® 68920	4 5/8"	.181



MB55 - 3 LEG

MB554 - 4 LEG

## MOTOR MOUNT BRACKET KIT

- Used with 5.5" motors
- Grommets and eyelets included
- Designed for applications with 9" or 10" bolt circle diameters.

## ECONOMIC MOTOR PROTECTION WITH FULL VOLTAGE RANGE & ADJUSTABLE IMBALANCE



### UNIVERSAL THREE-PHASE MOTOR PROTECTOR TPMPU

- Line Voltage: 180-600VAC
- Imbalance: Adjustable 4% to 20%
- Contact Type: SPDT 10A@240 VAC
- Short Cycle Adj: 10 Sec. to 5 Min.



### THREE-PHASE MOTOR PROTECTOR TPMP2

- Line Voltage: 208-277VAC
- Imbalance: Fixed 7%
- Contact Type: SPDT 5A@240 VAC

References to original equipment manufacturers' names, models, trademarks and part numbers are used for identification purposes only and SUPCO® replacement products are not in any way affiliated, endorsed or sponsored by such original equipment manufacturers.

# WE OFFER OVER 340 SKUs OF V-BELT TYPES

All belts clearly identify RMA classic part number and dimensionally equivalent FHP number.

SEE THE FULL OFFERING AT [SUPCO.COM](http://SUPCO.COM)  
SEARCH ON KEYWORD "BELT"



## MULTI-PLUS DUAL BRAND V-BELTS

### L SECTION FHP V BELTS

- 3/8" top width
- 7/32" thick

### A SECTION CLASSICAL V BELTS

- 1/2" top width
- 11/32" thick
- Dual brand A & 4L

### B SECTION CLASSICAL V BELTS

- 21/32" top width
- 13/32" thick
- Dual brand B & 5L

## LINEBACKER® SURGE PROTECTOR LBK10

### NEW AND IMPROVED

- Type 4x weatherproof enclosure can be mounted outside the condensing unit
- Type 2 surge protection device under UL standard 1449, 4<sup>th</sup> edition
- Uses state-of-the-art TPMOV technology
- The **ONLY** surge protector on the market to have voltage & ground monitors that will completely disconnect the equipment from power when compromised



## CONDENSATE PANS



Part No.	Capacity	Dissipation Rate Per Day
CP801	1 3/4 qt.	3 gal.
CP802	2 1/2 qt.	6 gal.
CP802-240	2 1/2 qt.	6 gal.
CP804	4 1/2 qt.	6 gal.
CP804-240	4 1/2 qt.	6 gal.
CP804HD	7 1/2 qt.	6 gal.
CP804HD-240	7 1/2 qt.	6 gal.
CP807	7 1/2 qt.	10 gal.
CP807-240	7 1/2 qt.	10 gal.
CP808	15 qt.	8 gal.
CP815	15 qt.	12 gal.
CP815-240	15 qt.	12 gal.
CP816	7 qt.	4.5 gal.
CP817	7 qt.	8 gal.
CP818	7 qt.	8 gal.
CP819	7 qt.	12 gal.
CP820	7 qt.	12 gal.
CP821	15 qt.	12 gal.

## CONDENSATE DRAINS



CAST ALUMINUM CONDENSATE DRAINS COMPLETE WITH LONG LIFE HEATING ELEMENT AND MOUNTING LEGS.

Part No.	Capacity	Volts	Watts	Rate	Size
70*	50 oz.	120	300	4 - 5 oz./hr	12 1/4" x 4 3/4" x 3"
75	75 oz.	120	320	14 oz./hr	10" x 9" x 2 3/4"
30-OS	38 oz.	120	160	8 oz./hr	10" x 4" x 2 7/8"
31	500 oz.	120	160	60 oz./hr	10" x 4 1/2" x 3 3/8"

\* NSF® Approved

## REPLACEMENT FLOATS



### CPFLOAT4

- Replaces CP Series Pans
- 4.5" Shaft



### CPFLOAT

- Replaces CP Series Pans
- 3" Shaft

## COMMERCIAL PAN MICROSWITCH



### CPS800



## HIGH PRESSURE OPEN ON PRESSURE RISE

Part No.	Open PSI (Cut Out)	Close PSI (Cut In)	Tolerance +/- PSI	Mars®	Johnson Controls®	Ranco®	Robertshaw®	R410A Application
SHP250150	250	150	15	33354/43322	N/A	N/A	N/A	
SHP250180	250	180	15		N/A	N/A	N/A	
SHP275195	275	195	15	33310/43324	P100CC9C	MPH7102	3100-112	
SHP300200	300	200	15	33355/43325	N/A	MPH7103	N/A	
SHP325225	325	225	15	43326	N/A	MPH7104	N/A	
SHP325230	325	230	15	33313	N/A	N/A	N/A	
SHP350250	350	250	15	33356/33316/ 43327	N/A	MPH71053101201/ 3100150		
SHP375265	375	265	15	33319/43328	N/A	MPH7106	3100111	
SHP400200	400	200	15	33357/43329	N/A	N/A	3100152	
SHP400280	400	280	15	33322/43330	N/A	N/A	N/A	
SHP400300	400	300	15	33358/33370	P100CA1C/ P100CP1C	MPH7107	3101202/3100151/ MG21-112	
SHP425300	425	300	15	33325/43332	N/A	N/A	N/A	
SHP425325	425	325	15	43333	P100CA2C/ P100CP2C	MPH7108	3100100/3100203/ MG211046	
SHP450250	450	250	15	33359/43334	N/A	N/A	N/A	
SHP480380	480	380	15	N/A	N/A	N/A	N/A	X
SHP550450	550	450	15	N/A	P100CE11D	N/A	N/A	X
SHP600475	600	475	15	33361/43335	N/A	N/A	N/A	X
SHP610420	610	420	15	43366/43376	N/A	N/A	N/A	X
SHP665565	665	565	15	N/A	P100CP85D	N/A	N/A	X
SLP90120	90	120	5	43375	N/A	N/A	N/A	X

## MANUAL HIGH PRESSURE OPEN ON PRESSURE RISE



Part No.	Open PSI (Cut Out)	Close PSI (Cut In)	Tolerance +/- PSI	Mars®	Johnson Controls®	Ranco®	Robertshaw®	R410A Application
SMR375	375	Manual	15	43312	P100DC3C	MPH7109	N/A	
SMR410	410	Manual	15	33365/43313	P100DA1C	MPH7110	3101301/3100103	
SMR440	440	Manual	15	33352/43315	N/A	N/A	3100104	
SMR575	575	Manual	15	43368	P100DA86D	N/A	N/A	X
SMR610	610	Manual	15	43369	N/A	N/A	N/A	X
SMR630	630	Manual	15	N/A	P100DA81C/D	N/A	N/A	X

References to original equipment manufacturers' names, models, trademarks and part numbers are used for identification purposes only and SUPCO® replacement products are not in any way affiliated, endorsed or sponsored by such original equipment manufacturers.





## LOW PRESSURE OPEN ON PRESSURE DROP

Part No.	Open PSI (Cut Out)	Close PSI (Cut In)	Tolerance +/- PSI	Mars®	Johnson Controls®	Ranco®	Robertshaw®
SLP0520	5	20	5	33329	P100AC1C	MPL7001	3101001
SLP0530	5	30	5	43342	N/A	N/A	3100002/MG201132
SLP1025	10	25	5	33330	P100AP201C	MPL7011	3100050
SLP1032	10	32	5	33330	P100AP201C	MPL7011	3100050
SLP1535	15	35	5	43371	P100AC2	MPL7002	3100001/MG201026
SLP2045	20	45	5	43345	N/A	N/A	3100003/MG201133
SLP2550	25	50	5	43372	N/A	MPL7012	MG212033
SLP2565	25	65	5	33336/43347	N/A	N/A	3101002
SLP2580	25	80	5	33363/43348	N/A	MPL7003	3101003/3100051
SLP2580	25	80	5	33363/43348	N/A	MPL7003	3101003/3100051
SLP3560	35	60	5	43349	N/A	MPL7004	3100004/MG201593
SLP4560	45	60	5	43351	P100AP2C	MPL7005	N/A
SLP4080	40	80	5	33364/43350	N/A	MPL7014	3101005/3100052
SLP5090	50	90	5	33339/43374	N/A	N/A	N/A
SLP75100	75	100	5	33342/43353	N/A	N/A	N/A
SLP90120	90	120	5	43375	N/A	N/A	N/A



## FAN CYCLE CLOSE ON PRESSURE RISE

Part No.	Open PSI	Close PSI	Tolerance	Mars®	Johnson Controls®	Ranco®	Robertshaw®	R410A Application
SFC75120	75	120	15	43301	N/A	MPF7006	N/A	
SFC110170	110	170	15	43302	N/A	MPF7007	N/A	
SFC125265	125	265	15	33340/43303	N/A	N/A	N/A	
SFC210275	210	275	15	33341	N/A	MPF7009	3101101/3100079	
SFC150225	150	225	15	43304	P100AP3C	MPF7008	N/A	
SFC170250	170	250	15	N/A	P100AP4C	N/A	N/A	
SFC200240	200	240	15	N/A	N/A	N/A	3100080	
SFC200365	200	365	15	N/A	N/A	N/A	N/A	X
SFC300400	300	400	15	43307	N/A	MPF7010	N/A	X
SFC275350	275	350	15					X

References to original equipment manufacturers' names, models, trademarks and part numbers are used for identification purposes only and SUPCO® replacement products are not in any way affiliated, endorsed or sponsored by such original equipment manufacturers.

## BPV SERIES BULLET PIERCING VALVES



\*BPV21, BPV31 and BPV31D are furnished with adapters for indicated multiple applications

Part No.	O.D. Tubing Size	Packaging
BPV31*	1/4", 5/16", 3/8"	12/Box
BPV31D*	1/4", 5/16", 3/8"	48/Box
BPV21*	1/2", 5/8"	8/Box
BPV14	1/4"	12/Box
BPV56	5/16"	12/Box
BPV38	3/8"	12/Box
BPV34	3/4"	1/Box
BPV78	7/8"	1/Box

## A1 & A2 ADJUSTABLE LINE TAP VALVES



Part No.	Tube Size O.D.	Packaging
A1	1/4", 5/16", 3/8"	12/Box
A2	1/2", 5/8"	12/Box

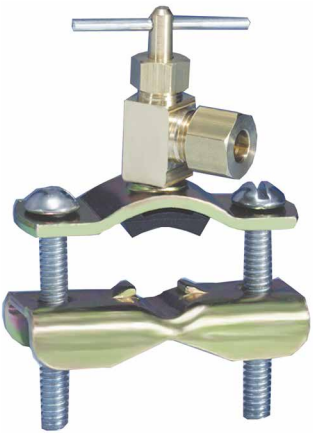

## SELF-TAPPING WATER VALVE STV2LL

• Fits 3/8" - 1 3/8" O.D. tubing or pipe

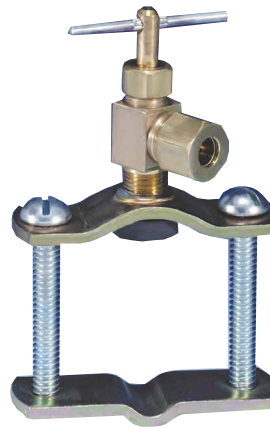

## CONVENTIONAL "DRILL" TYPE VALVE STV2DLL

• Includes all fittings for 1/4" O.D. Copper and plastic tubing



## ALLIN LIQUID EYE® MOISTURE REACTORS

- Easy to Read in Minimal Light
- When Moisture is Present, the Color Bars on the Band within the Tube Change Color
- Solid Brass Body
- Shock Resistant Glass
- Available in Flare or Solder
- Color Bar Designed for HFC Refrigerants



## ALLIN LIQUID EYE® SIGHT GLASSES

- Unique "See-Thru" feature that is more readable than other Sight Glasses
- Solid Brass Body
- Shock Resistant Glass
- Available in Flare or Solder
- Color Bar Designed for HFC Refrigerants



## SSG SERIES MOISTURE INDICATOR

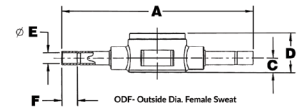

- 3% relative humidity sensitivity
- Maximum Working Pressure (MWP): 680 PSIG

## LIQUID LINE FILTER DRIERS



Part No.	Part No.
LLD032	LLD163
LLD032S	LLD163S
LLD052	LLD164
LLD052S	LLD164S
LLD053	LLD165
LLD053S	LLD165S
LLD082	LLD304
LLD082S	LLD304S
LLD083	LLD305S
LLD083S	LLD306S
LLD084	LLD307S
LLD084S	

## HP SERIES BI-DIRECTIONAL



Part No.
HP083
HP083S
HP163
HP163S
HP164
HP164S
HP165
HP165S

## SSLD SERIES SUCTION LINE DRIERS



Part No.	Part No.
SSLD83S	SSLD164
SSLD84S	SSLD305
SSLD85	SSLD305S
SSLD85S	SSLD306S
SSLD165S	SSLD309S
SSLD166S	SSLD419S
SSLD167S	SSLD83
SSLD307S	

## CSLD SERIES COMPACT SUCTION LINE DRIERS



Part No.
CSLD1454
CSLD1456
CSLD1457
CSLD1459

## DRIERS WITH UV DYE & MAGNETIC FILTERS

Part No.	Replaces
SUD8358	5303918288 & more



## SUD SERIES COPPER DRIERS



Part No.
SUD103
SUD109
SUD110
SUD111
SUD112
SUD113
SUD114
SUD115
SUD116

## COPPER STRAINERS

Specifically Designed for Re-opened Systems. Each Strainer Contains an Oversized Screen Area for Filtering Large Quantities of burnt out Foreign Matter from System.

Part No.	Inlet	Outlet	O.A. Length	O.D.	Feed
S210	1/4"	.098 Cap Tube	2 3/4"	3/4"	1
S211	1/4"	.125 Cap Tube	2 3/4"	3/4"	1
S212	1/4"	1/4" Copper Tube	2 3/4"	3/4"	1
S214	3/8"	.125 Cap Tube	4 1/2"	5/8"	2
S215	3/8"	.125 Cap Tube	4 1/2"	5/8"	3
S216	3/8"	3/8" Copper Tube	4 1/2"	5/8"	1
S218	3/8"	.125 Cap Tube	4 1/2"	5/8"	1
S219	3/8"	.146 Cap Tube	5"	7/8"	4
S220	3/8"	.112 Cap Tube	4 1/2"	7/8"	6
MD5	1/4"	Cap	1"		
MD6	3/8"	Cap	1"		



## BC SERIES BULLET® RESTRICTO CAPILLARY TUBING

Fits ANY Domestic and Commercial Refrigerator, Freezer or Application, Air Conditioner from 1/8 - 5 hp.

- Precision Bore, Plus or Minus .001"
- Specification: ASTM B360

**5PAK** - INCLUDES BC1, BC2, BC3, BC4, BC5

### Standard Service Packs

Part No.	Old Part No.	Length	Description
BC26X16		16 ft.	.026 ID X .071 OD
BC5		10 ft.	.028 ID X .071 OD
BC1	BC31X10	10 ft.	.031 ID X .081 OD
BC36X12		12 ft.	.036 ID X .086 OD
BC2	BC40X12	12 ft.	.040 ID X .093 OD
BC42X12		12 ft.	.042 ID X .093 OD
BC44X12		12 ft.	.044 ID X .093 OD
BC46X12		12 ft.	.046 ID X .093 OD
BC49X11		11 ft.	.049 ID X .093 OD
BC50X11		11 ft.	.050 ID X .093 OD
BC3	BC52X12	12 ft.	.052 ID X .093 OD
BC54X11		11 ft.	.054 ID X .106 OD
BC55X11		11 ft.	.055 ID X .112 OD
BC59X10		10 ft.	.059 ID X .112 OD
BC4	BC64X12	12 ft.	.064 ID X .125 OD
BC70X12		12 ft.	.070 ID X .125 OD
BC75X9		9 ft.	.075 ID X .125 OD
BC80X10		10 ft.	.080 ID X .145 OD
BC85X9		9 ft.	.085 ID X .145 OD
BC90X7		7 ft.	.090 ID X .145 OD

### 100 Foot Bulk Packs

Part No.	Old Part No.	Length	Description
BC26X100		100 ft.	.026 ID X .071 OD
BC5-100	BC28X100	100 ft.	.028 ID X .071 OD
BC1-100	BC31X100	100 ft.	.031 ID X .081 OD
BC36X100		100 ft.	.036 ID X .086 OD
BC2-100	BC40X100	100 ft.	.040 ID X .093 OD
BC42X100		100 ft.	.042 ID X .093 OD
BC44X100		100 ft.	.044 ID X .093 OD
BC46X100		100 ft.	.046 ID X .093 OD
BC49X100		100 ft.	.049 ID X .093 OD
BC50X100		100 ft.	.050 ID X .093 OD
BC3-100	BC52X100	100 ft.	.052 ID X .093 OD
BC54X100		100 ft.	.054 ID X .106 OD
BC55X100		100 ft.	.055 ID X .112 OD
BC59X100		100 ft.	.059 ID X .112 OD
BC4-100	BC64X100	100 ft.	.064 ID X .125 OD
BC70X100		100 ft.	.070 ID X .125 OD
BC75X100		100 ft.	.075 ID X .125 OD
BC80X100		100 ft.	.080 ID X .145 OD
BC85X100		100 ft.	.085 ID X .145 OD
BC90X100		100 ft.	.090 ID X .145 OD



## VIBRATION ABSORBERS



- Unique proven design for high pressure applications rated for R410A
- Compatible with all refrigerants
- Burst pressure 2500 (psig)
- 100% helium and hydrogen leak tested



Part No.	Tube Size O.D.	Length	Max Working Pressure PSI
VAS-012	1/2"	8 7/8"	500
VAS-014	1/4"	8"	500
VAS-034	3/4"	10 1/2"	500
VAS-038	3/8"	8 1/2"	500
VAS-058	5/8"	9 3/4"	500
VAS-078	7/8"	11 7/8"	500
VAS-118	1 1/8"	13"	500
VAS-138	1 3/8"	15 1/2"	500
VAS-158	1 5/8"	16 3/4"	500
VAS-218	2 1/8"	20 1/2"	390

## INDOOR AIR QUALITY



### IAQ50

Wall Mounted IAQ Monitor for continuous monitoring



### IAQ55

Handheld IAQ Monitor for pinpointing problem areas



### CO1000

CARBON MONOXIDE METER

- Up to 1000 ppm
- 1 ppm Resolution
- Audible Alarm
- Max and Data Hold
- Backlit LCD
- Boot and carrying case included

## SMOKE DETECTORS



### DUCTSD



Photoelectric 4-Wire Duct Smoke Detector

### D4120



Photoelectric 4-Wire Duct Smoke Detector - 120V

### D4120W



Watertight Photoelectric 4-Wire Duct Smoke Detector

### RTS2-AOS

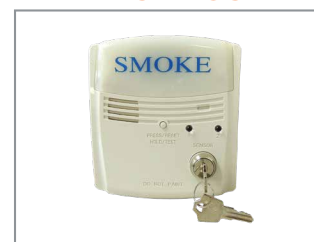

Multi-Signaling Accessory with Add-on Strobe

## INNOVAIRFLEX® DUCT SAMPLING TUBES

### DST



DST1: Ducts up to 1 ft.

DST1.5: Ducts 1.5 ft.

DST2: Ducts to 2 ft.

DST2.5: Ducts to 2.5 ft.

DST3: Ducts 2-4 ft.

DST5: Ducts 4-8 ft.

DST10: Ducts 8-12 ft.

DST22: Ducts 22 ft.

DST34: Ducts to 34 ft.

DST42: Ducts to 42 ft.

WE OFFER THE FULL LINE OF  
SYSTEM SENSOR® DETECTION



## REMOTE DIAL VAPOR TENSION THERMOMETERS

- Stainless Steel Housing
- Analog Dual Scale Dial °F or °C
- 48" Capillary
- Back Connection Mounting Points
- Temperature Range -40°F to 60°F (-40°C to 16°C)

Part No.	Dial Size	Flange
S6020BB	2"	Back
S6020FB	2"	Front
S6025FB	2.5"	Front
S6020HL	2"	Front
S6025HL	2.5"	Front



## SOLAR POWERED LCD THERMOMETER SSDF20

- Stainless steel housing
- Mounting: Surface front flange/ back connection
- Easy to read LCD display
- Range: -60°F to 160°F (-51°C to 71°C)

## TEMPERATURE / HUMIDITY PEN THP2



- -4°F to 122°F
- Humidity Range: 10% to 90%



## DUAL HAND HELD THERMOMETER PIT6L

- 6:1 Optical Ratio
- IR Range: -4°F to 518°F
- Ambient Range: 32°F to 122°F



## DUAL THERMOMETER LIT6P

- 6:1 Optical Ratio
- IR Range: -4°F to 518°F
- Probe Sensor Range: -58°F to 518°F



## LASER INFRARED THERMOMETER LIT11TC

- 11:1 Optical Ratio
- -76°F to 932°F



## SURE TEMP THERMOMETER ST1236-31

- Assures accurate reading
- Inexpensive solution
- Range: -40°F to 180°F
- Includes mounting hardware



## DIGITAL POCKET SURFACE THERMOMETER PT100

- Ultra sensitive probe
- Range: -40°F to 199.9°F
- Accuracy: 0.2 surface, 1.0 air

PT100 - °F  
PT100C - °C  
PT100H - High Temp °F



## THERMO-HYGROMETER W/ CLOCK THC120

- Measures temperature & humidity
- Tabletop or wall mount
- °F/°C switchable

## POCKET AND APPLIANCE THERMOMETERS

Part No.	Description	Temperature Range
ST01	Dial Pocket Thermometer, 1" Dial	40° to 160°F
ST02	Dial Pocket Thermometer, 1" Dial	0° to 220°F
ST03	Refrigerator Thermometer	-20° to 80°F
ST04	Oven Thermometer	100° to 600°F
ST06	Refrigerator Thermometer	-40° to 80°F
ST08	Dial Pocket Thermometer, 1 5/8" Dial	-40° to 160°F
ST09	Digital Pocket Thermometer	-40° to 392°F
ST10	Digital Pocket Thermometer	-50 to 392°F
ST11	Folding Digital Pocket Thermometer	-58° to 572°F



ST06



ST09



ST10



ST11

# CLEANERS



SPORE GO® BROAD SPECTRUM CLEANER

**HS53128**

- Cleans Away Mold and Mildew
- Australian Tea Tree oil
- Mitigates Moisture and Water Damage
- Multi-Surface, Broad Spectrum Cleaner
- Coil Cleaner - Evaporator and Condenser
- 4/case



ICEMAX® NICKEL SAFE ICE MACHINE CLEANER

**HS50004**

- 12 per case



GREEN PAN TABS

**HS52200**

- Economical Condensate Drain Pan Treatment
- 12/case



COILMAX® COIL CLEANER

**HS56008**

- 16 oz. jar
- Sold 12/case

PINK STUFF - ACID BASED COIL CLEANER  
GREEN STUFF - ALKALINE BASED COIL CLEANER



Part No.	Size	PKG
HS58128	1 gal.	4/case
HS58520	18 oz. can	12/case
HS59128	1 gal.	4/case
HS59520	19 oz. can	12/case



SUPER FLUSH AC/R INTERNAL SYSTEM CLEANER

12/case	Size	PKG
HS55032	32 oz.	12/case
HS55128	1 gal.	6/case

## DETECTORS AND TESTERS



Kit	Name	Description
HS22008	Gas Leak Detect - Low	8 oz. 12/case
HS22032	Gas Leak Detect - Low	32 oz. 12/caseHS
HS23008	Gas Leak Detect - Mid	8 oz. 12/case
HS23032	Gas Leak Detect - Mid	32 oz. 12/caseHS
HS23128	Gas Leak Detect - Mid	Gallon 12/case
HS16001	The Acid Test	4 tests per kit; 12 per case
HS16501	Oil Checker	Two test per kit; 12/case
HS20004	Trace® Leak Detect	4oz. 12/case
HS20016	Trace® Leak Detect	16 oz. 12/case
HS21004	Trace 2® Leak Detect	4 oz. 12/case
HS21016	Trace 2® Leak Detect	16 oz. 12/case

## HIGHSIDE® QUICK SERVICE KITS

- 6 per case



Kit	Name	Description
HS18002	Acid Neutralizer	2 oz.
HS18022*	Acid Neutralizer	Kit Refill - 2 pre-charged injectors
HS19002*	PRO-A	Frees sticky expansion valves
HS19022*	PRO-A	Kit Refill - 2 pre-charged injectors
HS60002*	AC Leak Repair	All-in-one lubricator w/ UV dye
HS60022*	AC Leak Repair	Kit Refill - 2 pre-charged injectors
HS21002*	Trace 2	2 oz. pre-charged red UV injector
HS21022*	Trace 2	Kit Refill - 2 pre-charged injectors
HS17002	Thawzone	2oz. pre-charged injector; 4/case
HS17022*	Thawzone	Kit Refill - 2 pre-charged injectors

## LEAK LOCK® & LEAK LOCK® GOLD BRUSHABLE PASTE WITH TEFLON JOINT COMPOUND

Leak Lock® No.	Leak Lock® Gold No.	Dimensions
HS10001	HS11001	1-1/3 oz Tube
HS10004	HS11004	4 oz. Brush Top Plastic Jar
HS10016	HS11016	16 oz. Brush Top Plastic Jar

• 12 per case



## LEAK LOCK ONE STEP PVC CEMENT

The only no primer, fast setting, all weather low VOC One step PVC Cement

Part No.	Dimensions
HS10604	4 oz. metal bottle
HS10608	8 oz. metal bottle

- Works on WET, dry & flexible pipe
- Allows immediate pressure testing
- Meets ASTM D2564
- 12 per case



## THREAD SEALANT

Single Packs  
HS10002 - Blue  
HS11002 - Gold



## HVAC SUPER PRO SOLDERLESS BONDING KIT

HS32098

• 12 per case



## JUST FOR COPPER PRO

HS31058

• 12 per case



## THREADLOCKER®

HS13001

• 12 per case



## HVAC INSTANT PATCH

HS32032

• 12 per case



## FCC-PRO

EVAPORATOR COIL CLEANER & DISINFECTANT

- No rinse foaming evaporator coil cleaner and disinfectant
- EPA Approved Virucidal that has multiple uses
- EPA Reg. No. 44446-23-6381
- 18oz., 12/case



## DIPA-1

### DISINFECT PRO AEROSOL HOSPITAL GRADE DISINFECTANT

- EPA Approved Virucidal
- Tuberculocidal
- Fungicidal
- Aerosol Disinfectant & Deodorizer
- Designed for industrial, institutional, commercial, medical, and residential facilities, equipment, and vehicles, including hospitals, ambulances, nursing homes and more
- EPA Reg. No. 44446-67-6381
- 16.5oz., 12/case